Crystalline Silicon PV Module Installation Guide

1. Introduction

1.1 *Purpose*

1.2 *Limitation of Liability*

2. Safety

2.1 *General Safety*

2.2 *Installation Safety*

3. Mechanical Installation

3.1 *Installation Condition*

3.2 *Installation Methods*

4. Electrical Installation

4.1 *Installation Condition*

4.2 *Grounding*

5. Maintenance and disposal

1. Introduction

1.1 Purpose

This document provides detailed instructions and valuable safety information regarding the installation, electrical connection, and maintenance of the following ASTRONERGY Crystalline Photovoltaic modules:

CHSM5409M	CHSM5611M	CHSM5612M	CHSM6609M	CHSM6610M
CHSM6609P	CHSM6610P	CHSM6611P	CHSM6612P	

All instructions and mechanical and electrical requirements should be read and understood before attempting installation. The installer should conform to all safety precautions in this guide when installing the module. Keep this guide in a safe place for further reference.

1.2 Limitation of Liability

Because the use of this manual and the conditions or methods of installation, operation, use and maintenance of photovoltaic (PV) products are beyond Astronergy's control, Astronergy does not accept responsibility and expressly disclaims liability for loss, damage, or expense arising out of or in any way connected with such installation, operation, use or maintenance. Astronergy reserves the right to change the manual without prior notice.

2 Safety

2.1 General Safety

- 2.1.1 Consult and follow local codes and other applicable laws concerning required permitting as well as installation & inspection requirements, rules, and regulations.
- 2.1.2 PV modules should be installed and maintained by qualified personnel.
- 2.1.3 Use the same performance modules within a given series.
- 2.1.4 Follow all safety precautions of all components used in the system.
- 2.1.5 Do not shade portions of the PV module surface from the sun for a long period of time. The shaded cell may become hot (hot spot phenomenon), which can result in solder joints peeling off.
- 2.1.6 Do not clean the glass surface with chemicals.
- 2.1.7 Do not drop the PV module or drop objects onto the PV module.
- 2.1.8 Do not concentrate sunlight on the modules or panels.
- 2.1.9 Do not attempt to disassemble the modules, and do not remove any attached components from the modules.
- 2.1.10 Do not scratch or hit at the back sheet, the glass, the terminal box. Do not pull the cables or touch them with bare hands.
- 2.1.11 Do not drill holes in the frame or scratch the insulating coating of the

frame.

- 2.1.12 Keep the PV module packed in the carton until installation.
- 2.1.13 Do not use modules near equipment or in places where flammable gases may be generated.

2.2 Installation Safety

- 2.2.1 Wear protective head gear, insulating gloves, safety shoes, and insulated tools when installing the modules.
- 2.2.2 Do not install the modules in rain, snow, or otherwise wet or windy conditions.
- 2.2.3 Completely cover the PV module surface with an opaque material during PV module installation and wiring to prevent accidental charge buildup.
- 2.2.4 Plug in connectors tightly when working on wiring.
- 2.2.5 Due to the risk of electrical shock, do not perform any work if the terminals of PV module are wet.
- 2.2.6 Do not touch the terminal box and the end of output cables (connectors) with bare hands.
- 2.2.7 Do not unplug the connector under load.
- 2.2.8 Do not work alone.
- 2.2.9 Wear a safety belt if working far above the ground.
- 2.2.10 Do not wear metallic jewelry, which can cause electric shock, while installing or troubleshooting the PV system.
- 2.2.11 Follow the safety regulations for any and all other system components, including wires, connectors, charging regulators, batteries, inverters, etc.
- 2.2.12 Do not expose wires to direct sunlight. Use UV-resistant cabling.
- 2.2.13 Do not damage the surrounding PV modules or mounting structure when replacing a PV module.
- 2.2.14 Do not change any PV module components (diode, junction box, plug connectors, etc.).

3 Mechanical Installation

3.1 Installation Conditions

- 3.1.1 Environment temperature: -40 to 85 °C
- 3.1.2 Operating temperature: -40 to 85 °C
- 3.1.3 Mechanical load on panels (e.g., from wind or snow): less than 5400 Pa
- 3.1.4 Tilt Angle selection: The installation must be facing north in the southern hemisphere and facing south in the northern hemisphere.
- 3.1.5 To maintain the modules' Class C fire rating, there must be at least 115 mm of space between the module frame and the mounting surface of the roof to allow for cooling air to circulate around the back of the module.

The fire class of the roof and building materials should higher than Class C.

3.2 Installation Methods

3.2.1 Bolts

All modules must be securely fastened with at least 4 bolts. For maximum security against strong winds or heavy snow falls, all 6 mounting holes (modules CHSM5409M, CHSM6609M/P, and CHSM6610M/P; see figure 1a) or 8 mounting holes (CHSM6611P and CHSM6612P; figure 1b) should be used.

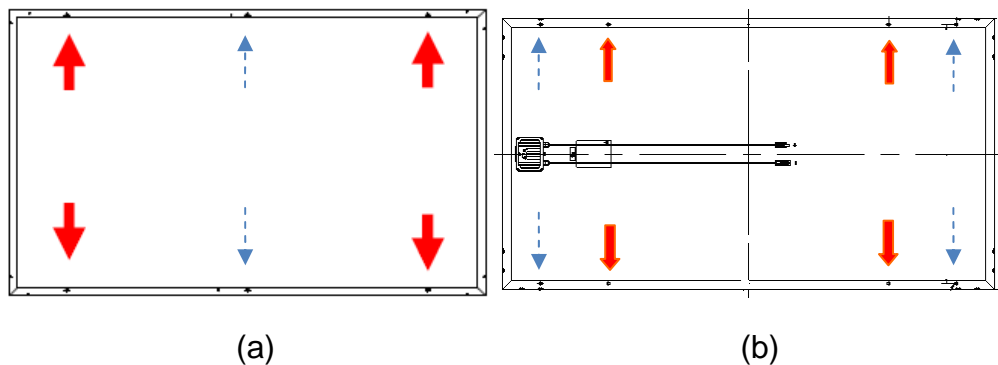

Figure 1. Bolt positions for the at-minimum four-bolts for a) modules CHSM5409M, CHSM6609M/P, CHSM6610M/P; and b) modules CHSM6611P and CHSM6612P. Solid red arrows indicate primary bolt positions; dashed blue arrows indicate positions where bolts can be added for additional support.

Bolts are inserted as described in the process below (see figure 2).

1. Place the module on the frame.
2. Insert four stainless-steel bolts (M6) through the holes (7x11.5mm) in the frame according to figure 1. For maximum security against strong winds and heavy snow, all available mounting holes should be used.
3. Secure each bolt to the frame with 2 stainless-steel washers, one on each side of the mounting structure; and screw on either a stainless-steel spring washer or a toothed lock washer. Finally, secure with a stainless steel nut (M6).
4. Tighten to a torque of approximately 15 - 20 Nm.

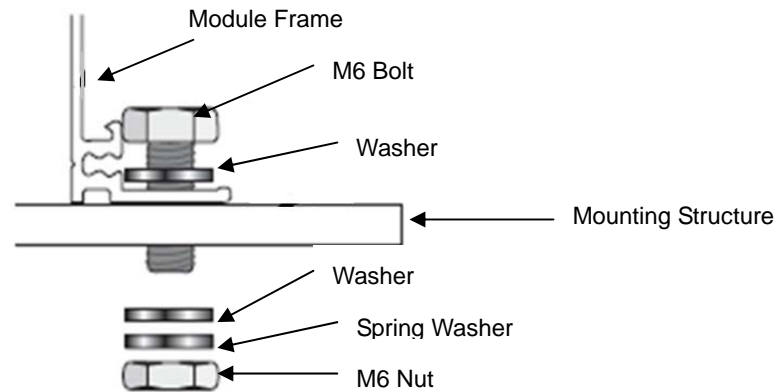

Figure 2. Securing the module with bolts.

3.2.2 Clamping with type-1 clamps (aluminum alloy)

Modules can be laid either across the supporting bars (figure 3a) or parallel to them (figure 3b).

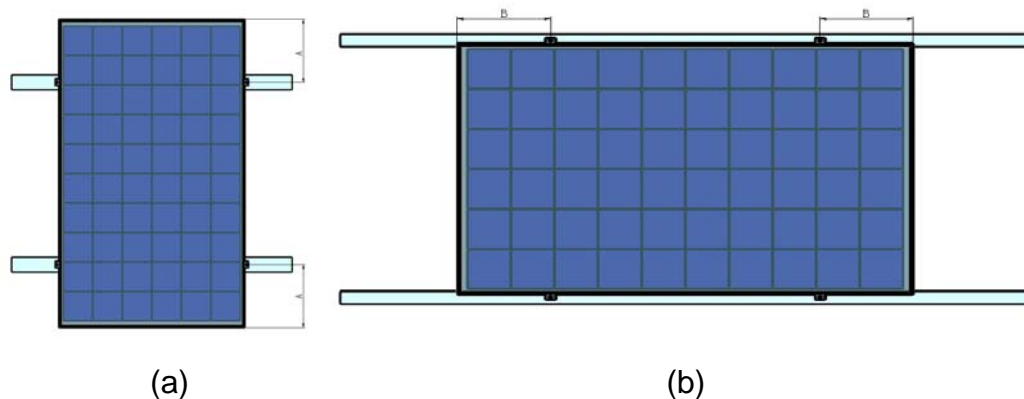

Figure 3: Illustrations of the two different methods for clamping modules onto the frame with aluminum clamps.

Each aluminum mounting clamp comes with an M8 bolt, a plain washer, a spring washer, and an M8 nut. To fasten the module:

1. Lay the module on the two supporting bars (not provided) with a standoff height of at least 115 mm. The bars should be made with stainless material or treated with an anti-corrosion process (e.g., anodic oxidation treatment).
2. The bar's top surface contacted with module frame should come with grooves compatible with an M8 bolt.
3. Slide bolts through groove on the supporting bars next to the locations where the 4 clamps are to be fastened. The clamps are normally located $\frac{1}{4}$ of the frame length away from the shorter edge (as illustrated in figure 4).
4. If the bars do not come with grooves, holes of a suitable diameter may need to be drilled to allow bolts to be attached to the bars at the same

locations as mentioned before.

5. Secure each clamp by attaching plain washer, spring washer, and nut, in that order.
6. Tighten the nut with a torque wrench to 15 – 20 Nm.

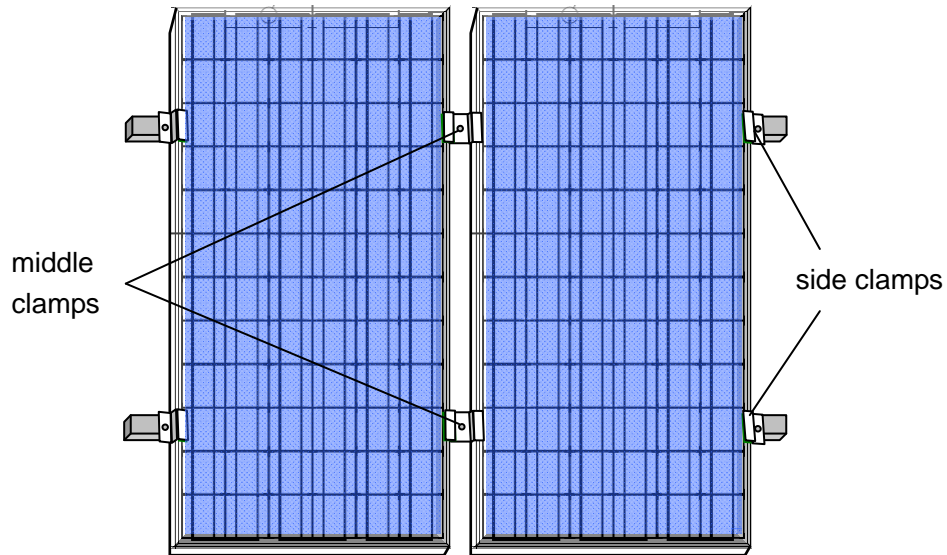

Figure 4. Placement of middle and side clamps on the modules.

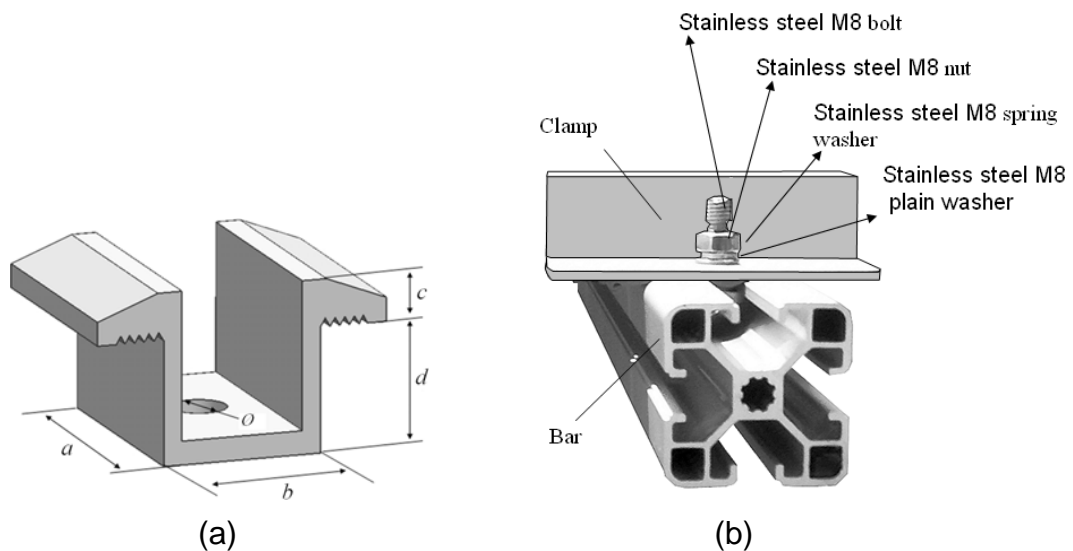

Figure 5. Close-ups of middle (a) and side (b) aluminum clamps. The dimensions for the middle clamps are $a \geq 40$ mm, $b \geq 26$ mm, $c = 8$ mm, $d \geq 28$ mm, and $\phi = 9$ mm.

3.2.3 Clamping with type-2 clamps

To install, place the module on the mounting rail and clamp in place with the module clamp (see figure 6). Recommended tightening torque is 8 Nm (70 Inch Pounds). It is important to note that:

1. The module may be clamped only in the permitted clamping areas on the long edge of the frame. Never clamp the short edge of the frame. For exact locations on the frame refer to figure 7 in conjunction with table 1 below.
2. The module clamps must not overlap the glass or shade the module surface and must clamp at least 40 mm or 1 1/2" along the edge of the frame.

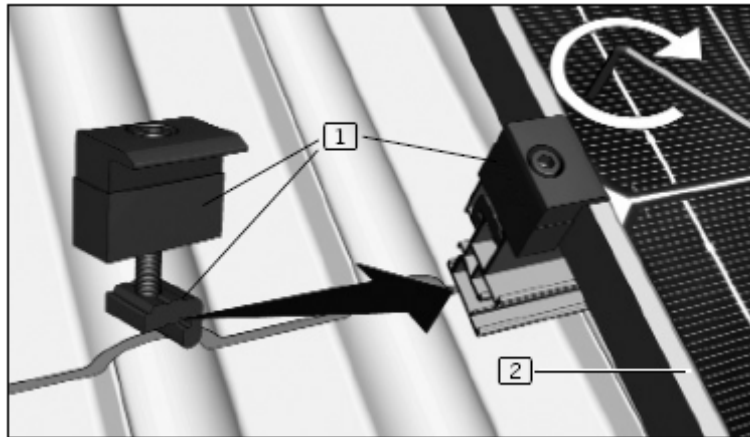

Figure 6. Clamping with type-2 clamps.

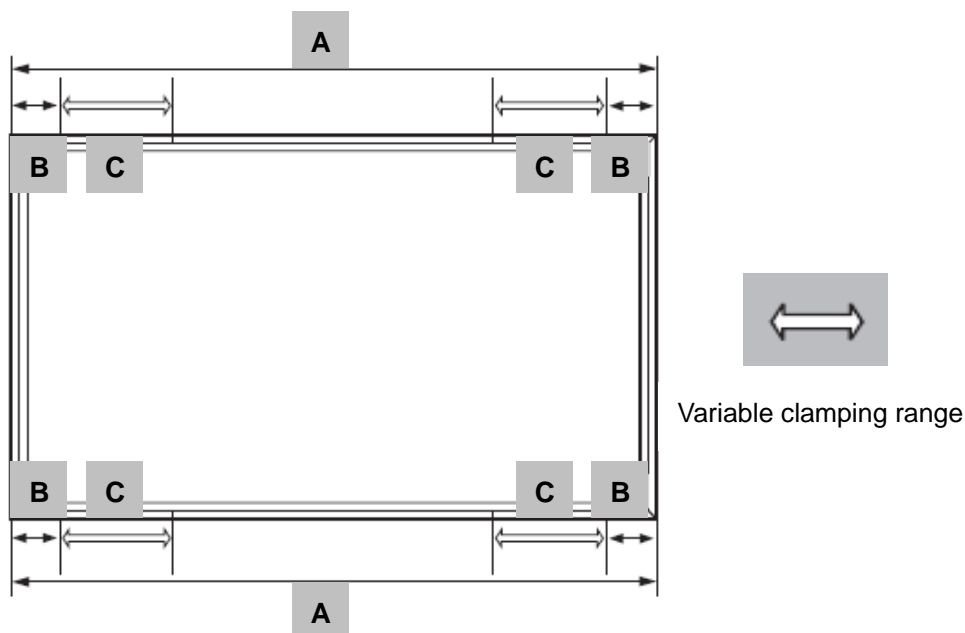

Figure 7. Permitted clamping locations with the type-2 clamp. For exact dimensions for a given module series, see table 1 (below).

Table 1. Use in conjunction with figure 7 to determine permitted clamping locations for a given module series for clamping with type-2 clamps.

Module Series	Dimension	A	B	C
CHSM5409M	1200*554*35	1200	50	300

CHSM5612M	1580*808*45	1580	50	300
CHSM6609M/P	1494*994*45	1494	50	300
CHSM6610M/P	1652*994*45	1652	50	300
CHSM6611P	1798*994*50	1798	60	355
CHSM6612P	1956*994*50	1956	60	355

4 Electrical Installation and Grounding

4.1 Installation

- 4.1.1 The electrical characteristics are within ± 10 percent of the indicated values of I_{sc} , V_{oc} and P_{mp} under test conditions (irradiance of 100 mW/cm², AM1.5 spectrum, and a cell temperature of 25°C).
- 4.1.2 The maximum system voltage for all module series is 600 V for North American Market and 1000V for European Market.
- 4.1.3 Connect quantity of modules that match the voltage specifications of the inverters used in system. Modules must not be connected together to create a voltage higher than the permitted maximum system voltage under the worst local temperature conditions.
- 4.1.4 Under normal conditions, a photovoltaic module is likely to experience conditions that produce more current and/or voltage than reported at standard test conditions. Accordingly, the values of I_{sc} and V_{oc} marked on this module should be multiplied by a factor of 1.25 when determining component voltage ratings, conductor ampacities, fuse sizes, and size of controls connected to the PV output.
- 4.1.5 Refer to Section 690-8 of the National Electrical Code for an additional multiplying factor of 125 percent (80 percent derating) which may be applicable.
- 4.1.6 Each module (or series-connected string of modules) shall be provided with the maximum series fuse, specified as 10 A for the 5 inch cell module series and 15 A for the 6 inch cell module series.
- 4.1.7 Use a special solar cable and plugs for installing the PV system and make sure that all connections are safe and tight. The cable should be 4 mm² (12 AWG), and able to withstand the maximum possible system open-circuit voltage.
- 4.1.8 Bypass diodes are included in module junction boxes to avoid decreased module performance in the event of shade or shelter. The number of diodes in each module series is given in table 2.

Table 2. Number of junction-box bypass diodes for a given module series.

Module Series	Number of diodes
CHSM 5409M	3
CHSM 5612M	3
CHSM 6609M/P	6
CHSM 6610M/P	6
CHSM 6611P	6
CHSM 6612P	6

4.2 Grounding

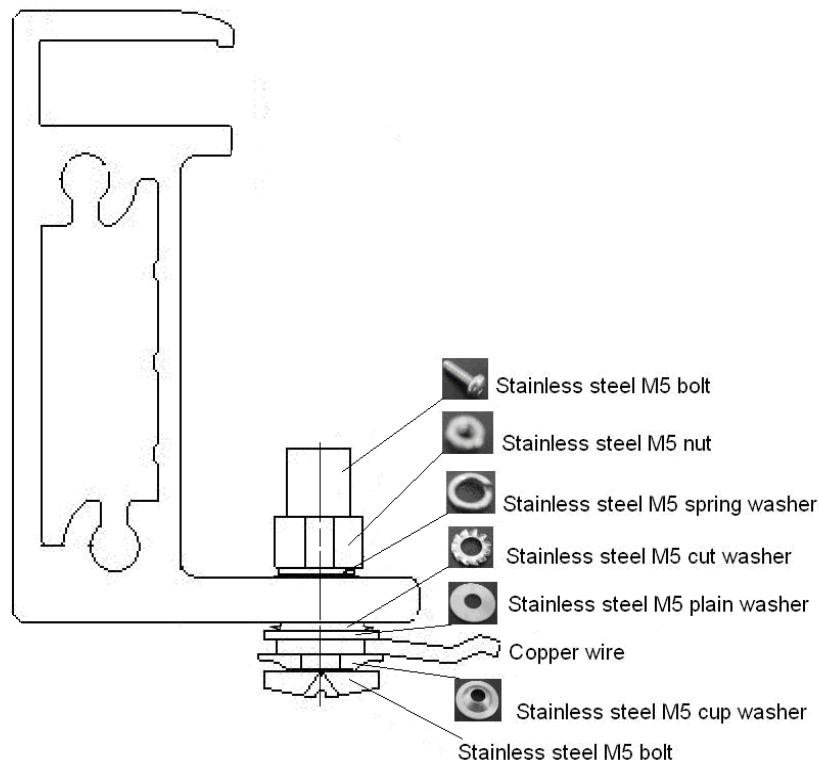

Figure 8. Grounding the aluminum frame with copper wire.

- 4.2.1 Use the marked 5.5 mm grounding holes (5.5mm) to ground the anodized frame. Use an M5 nut, two M5 cut washers, an M5 plain washer, an M5 spring washer, and an M5 bolt and a copper wire. All nuts, bolts, and washers are type M5 and should be made of stainless steel (as in figure 8).
- 4.2.2 Put the bolt through the cup washer and wrap the copper wire around the bolt. (Note that the copper wire cannot be attached directly to the aluminum.)
- 4.2.3 Put the bolt through the cut washer and then through the hole in the aluminum frame.
- 4.2.4 Add the spring washer and nut on the other side of the bolt and tighten to secure all parts. The tightening torque should be $210 \pm 20 \text{ N} \cdot \text{cm}$.

5 Maintenance

- 5.1 Regularly carry out a visual inspection for dirt, dust, bird dropping, leaves, and other detritus covering the modules.
- 5.2 If there is a build-up of dirt or dust on the module surface, wash the module with clean water and a gentle implement (a sponge). Never use chemicals on the surface of the module.
- 5.3 If snow is present, a soft-bristled brush with soft bristles may be used to clean the surface of the modules.
- 5.4 Regular electrical and mechanical inspection by a licensed professional will keep the system safe and operating at maximum efficiency.

CHINT SOLAR (ZHEJIANG) Co., Ltd.

Add: 1335 Bianan Rd, Binjiang District, Hangzhou, China 310053

Tel: 86-571-5603 1888 Fax: 86-571-5603 2333

<http://www.astronergy.com>